

DISCHARGE LAMPS

Powerstar HQI-E/P, HQI-E and HQI-T (Metal Halide Lamps)



Product Features:

- HQI-E/P and HQI-T:** Powerstar Quartz Technology
- Light Colours:** *Daylight (D) for HQI-E/P
*Neutral White (N), Daylight (D) for HQI-T
- HQI-E:** Reduced Material Load within the Luminaire
UV Filter on Lamp Complies with Requirements of IEC 61167

General Data:

Product Benefits:

- Powerstar HQI-E/P and Powerstar HQI-T** *High efficiency
*UV values significantly below the maximum permitted thresholds to IEC 61167 thanks to UV filter
- Powerstar HQI-E** *E27 Screw base for simple lamp handling
*Different Colours

Typical Applications: Lighting

- *Shopping arcades
- *Outdoor applications only in suitable luminaires
- *Factories and workshops
- *Pedestrian zones, public squares (HQI-E/P and HQI-E)
- *Airports, docks, port facilities (HQI-T)

Colour Type:

| | Sky White | Cool Daylight | Daylight | Cool White | White | Warm White | INTERNA | Special Light Colours | | |
|-------|-----------|---------------|----------|------------|--------|------------|---------|-----------------------|--------|--------|
| Code: | 880 | 865 | 965 | 954 | 840 | 940 | 835 | 830 | 830 | 827 |
| | 8 000 K | 6 500 K | 5 400K | 5 400K | 4 000K | 4 000K | 3 500K | 3 000K | 3 000K | 2 700K |



Technical Information and Photographs from OSRAM
Selected Information has been Edited by ACTOM Electrical Products

Address: 4 Branch Road, Germiston 1401, P.O. Box 678, Germiston 1400

Email: aep.enquiries@actom.co.za

Tel: +27 11 878 3050

Website: www.actomep.co.za

DISCHARGE LAMPS

Powerstar HQI-E/P, HQI-E and HQI-T (Metal Halide Lamps)

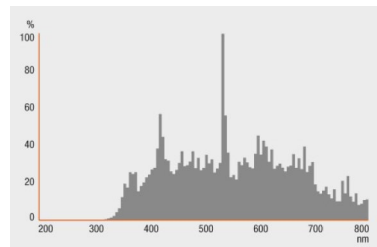
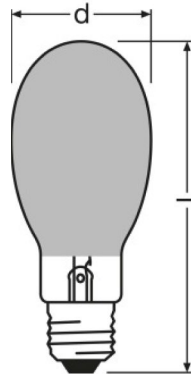

HAL PRO R50 30 W 230 V E14,
HAL PRO R50 30 W 240 V E14

HAL PRO R50 30 W 230 V E14,
HAL PRO R50 30 W 240 V E14

Product Information for Powerstar HQI-E/P:

| Product Description | W | V | Length | Diameter | Lumen | CCT | CRI | Rated Ave Life | EEC |
|---|-----|-----|--------|----------|--------|-----|-------|----------------|-----|
| | | | (mm) | (mm) | (lm) | (K) | (Ra) | (h) | |
| HQI-E/P 250 W/D CO GES (code:55825G) | 250 | 98 | 226 | 91 | 17 000 | 90 | 5 300 | 9 000 | A |
| HQI-E/P 400 W/D CO GES (code:55820G) | 400 | 110 | 290 | 122 | 32 000 | 90 | 5 100 | 16 000 | A |



Technical Information and Photographs from OSRAM
Selected Information has been Edited by ACTOM Electrical Products

Address: 4 Branch Road, Germiston 1401, P.O. Box 678, Germiston 1400

Email: aep.enquiries@actom.co.za

Tel: +27 11 878 3050

Website: www.actomep.co.za

DISCHARGE LAMPS

Powerstar HQI-E/P, HQI-E and HQI-T (Metal Halide Lamps)



Powerstar HQI-E
Clear,
for Open and
Enclosed Luminaires

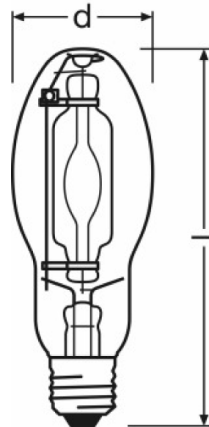

HQI-E 70 W/NDL CL,
HQI-E 100 W/NDL CL,
HQL-E 150 W/NDL CL

Product Information for Powerstar HQI-E:

| Product Description | W | V | Length (mm) | Diameter (mm) | Lumen (lm) | CCT (K) | CRI (Ra) | Rated Ave Life (h) | EEC |
|---------------------|-----|---|----------------|------------------|---------------|------------|-------------|--------------------------|-----|
| HQI-E 70 W/NDL CL | 70 | - | 141 | 55 | 5 500 | 4 200 | 80 | 6 000 | A |
| HQI-E 100 W/NDL CL | 100 | - | 141 | 55 | 8 400 | 4 200 | 82 | 6 000 | A |
| HQI-E 150 W/NDL CL | 150 | - | 141 | 55 | 11 000 | 4 200 | 88 | 6 000 | A |



Technical Information and Photographs from OSRAM
Selected Information has been Edited by ACTOM Electrical Products

Address: 4 Branch Road, Germiston 1401, P.O. Box 678, Germiston 1400

DISCHARGE LAMPS

Powerstar HQI-E/P, HQI-E and HQI-T (Metal Halide Lamps)



Powerstar HQI-T
1000...2000 W,
for Enclosed
Luminaires

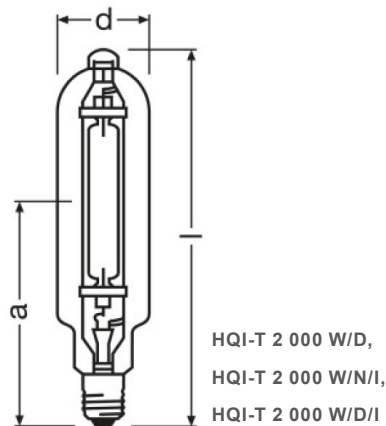

Product Information for Powerstar HQI-T:

| Product Description | W | V | Lamp Current | Length | Diameter | Lumen | CCT | CRI | Rated Ave Life | EEC |
|---------------------------------------|-------|-----|-----------------|--------|----------|---------|-------|------|-------------------|-----|
| | | | (A) | (mm) | (mm) | (lm) | (K) | (Ra) | (h) | |
| HQI-T 2 000 W/D External Ignitor | 2 000 | 230 | 10.3 | 430 | 100 | 18 000 | 7 250 | 80 | 9 000 | A+ |
| HQI-T 2 000 W/N/I Internal Ignitor | 2 000 | 235 | 8.8 | 430 | 100 | 200 000 | 4 300 | 60 | 9 000 | A+ |
| HQI-T 2 000 W/D/I Internal Ignitor | 2 000 | 230 | 10.3 | 430 | 100 | 180 000 | 7 450 | 83 | 9 000 | A |



Technical Information and Photographs from OSRAM
Selected Information has been Edited by ACTOM Electrical Products

Address: 4 Branch Road, Germiston 1401, P.O. Box 678, Germiston 1400

Email: aep.enquiries@actom.co.za

Tel: +27 11 878 3050

Website: www.actomep.co.za

Complete your Project:

Please select the items you require and we will be in touch

Cables and Wires:

Indoor
Outdoor
General
Other
Let an ACTOM
Specialist Contact you

Lighting:

Indoor
Outdoor
General
Other
Let an ACTOM
Specialist Contact you

Transformers (Distribution):

Indoor
Outdoor
General
Other
Let an ACTOM
Specialist Contact you

Accessories:

Indoor
Outdoor
General
Other
Let an ACTOM
Specialist Contact you

Specific Information:

Address: 4 Branch Road, Germiston 1401, P.O. Box 678, Germiston 1400

For more Information on this Product Please Send us the Following

Product Information:

Product Name:

Quantity:

Project Name:

Date the Product is required:

Your Contact Information:

Name and Surname:

Company:

Email:

Phone Number:

Province:

Thank You

For having a Look at this Product

Please send this PDF back to us with all your Information

Scan the QR Code to visit our Website:

